



## TWO SEATER SPACE LOUNGE CHROME WRAP AROUND FRAME

- Chrome Wrap Around Frame - 280 Kg Weight Rating
- Black PU Leather Upholstery Throughout - Adjustable Feet For Levelling Purposes
- Tested To BS EN 12520:2015 Standard

---

**SKU:** SPACE2

### GALLERY IMAGES

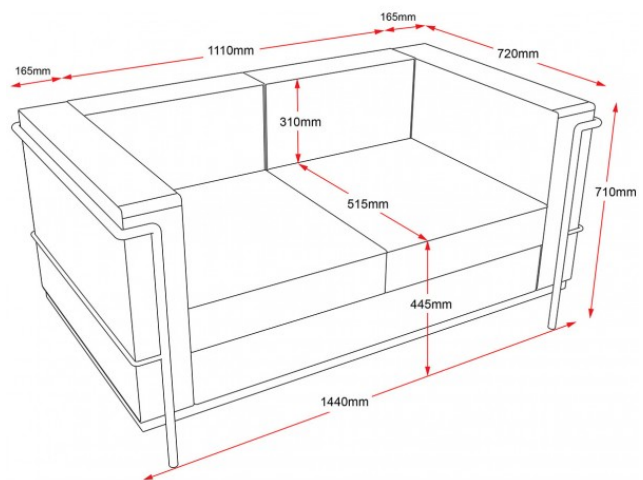

## PRODUCT DESCRIPTION

Enhance your reception area with this timeless design. Two seater arm chair with chrome frame and feet and upholstered in cleanable black PU.

Backed by a 3 year warranty.

### Finishes:



### Specifications

SKU	BACK HEIGHT	SEAT DEPTH	SEAT WIDTH	SEAT HEIGHT
SPACE2	310mm	515mm	1110mm	445mm

### Box Dimensions

Box Number	Width	Depth	Height	CBM	Weight
1	720mm	1450mm	780mm	0.81	51kg



Q Office Furniture  
02 63 62 3530  
enquiries@qof.com.au  
www.qof.com.au